

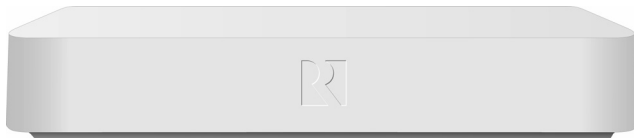

BGB2 iBridge Bay

Instruction Manual



Safety Precautions

1. Read these instructions.
2. Keep these instructions.
3. Heed all warnings.
4. Follow all instructions.
5. Do not use this apparatus near water.
6. Clean only with dry cloth.
7. Do not block any ventilation openings. Install in accordance with the manufacturer's instructions.
8. Do not install near any heat sources such as radiators, heat registers, stoves, or other apparatus (including amplifiers) that produce heat.
9. Do not defeat the safety purpose of the polarized or grounding plug. A polarized plug has two blades with one wider than the other. A grounding plug has two blades and a third grounding prong. The wide blade or the third prong is provided for your safety. If the provided plug does not fit into your outlet, consult an electrician for replacement of the obsolete outlet.
10. Protect the power cord from being walked on or pinched, particularly at plugs, convenience receptacles, and the point where it exits from the apparatus.
11. Use only attachments or accessories specified by the manufacturer.
12. Use only with the cart, stand, tripod, bracket, or table specified by the manufacturer or sold with the apparatus. When a cart is used, use caution when moving the cart-apparatus combination to avoid injury from tip-over.
13. Unplug this apparatus during lightning storms or when unused for long periods of time.
14. Refer all servicing to qualified service personnel. Servicing is required when the apparatus has been damaged in any way, such as the power supply cord or plug is damaged, liquid has been spilled or objects have fallen into the apparatus, or the apparatus has been exposed to rain or moisture, does not operate normally, or has been dropped.

If you have any questions, call Russound at 800.638.8055 or 603.659.5170.



Product Information

Product Overview	4
------------------------	---

Operation

UNO-TS2 Touchscreen Control	5
SRC2 Remote Control Function Keys	6-9
UNO-S2 Keypad Control	10

Installation

Installing iBridge Bay Application	11
Rear View	12
Installing Hardware	13-14
Connection Overview Diagram	15

Troubleshooting

System Troubleshooting	16-18
------------------------------	-------

Specifications and Warranty

Specifications and Warranty	19
-----------------------------------	----

Product Information

Product Overview

The iBridge Bay (BGB2) is a table-top device that allows you to use an Apple® Mac® computer as a remote source for a Russound RNET® multiroom system. Used with a Russound RNET A/V Decoder, it provides RNET access to a Mac's iTunes® media library.

With a Russound RNET system, the Bay treats the iTunes media library as a fully functional RNET smart source. It gives the system's keypads, touchscreens, and remote controls full control of iTunes: Play, Pause, Next Song, Previous Song, Playlist Up, and Playlist Down. The UNO-TS2 touchscreen adds the ability to select music by playlist, genre, artist, album, and song.

The iBridge Bay also enables program information to display on the RNET system's keypads and touchscreens. They show playlist, artist, album, and song title information from iTunes.

The iBridge Bay uses Russound software (iBridge

Bay Application) to interface with iTunes on the Mac. The Mac uses Front Row, a user interface for media (music, video, DVD) selection on the Mac. The default settings for the iBridge Bay launches the Mac's Front Row interface and the iBridge Bay on startup.

The iBridge Bay can be used two different ways in an RNET multiroom system. It can be used as an audio only source in audio zones, or it can serve as an audio and video source, also displaying video, photos, and movies in multiroom zones equipped with a video display.

When used in zones with a video display, you can use a Russound SRC2 remote control aimed directly at a keypad or touchscreen to directly control Front Row on the Mac while watching changes occur on the video display.

The iBridge Bay supports Mac models running OS X 10.4 or higher and iTunes. It connects via a single CAT-5e cable to an RNET A/V Decoder at the system controller.



UNO-TS2 Touchscreen Control

An UNO-TS2 touchscreen provides the most complete control and feedback option for iTunes. The touchscreen allows navigation through the menus in iTunes to select music by playlist, genre, artist, album, and song. It also displays current selections. *Note:* UNO-TS2 screen version 2.00.01 is required for use with iBridge Bay.

Once you select the iBridge Bay from the home screen, you reach the Bay screens. From the screen you can scroll through playlists by pressing the + and - hard keys to the right of the display, or select the next or previous song with the song >| or |< hard key. You can also press the Shuffle soft key to toggle Shuffle off and on.

Pressing the Music soft key displays the Request screen (right) to access music through any of the five categories. Selecting any one of the categories allows you to quickly navigate through your music.

Note: Shared playlists appear with the first four letters of the “Shared Name” as a prefix to the playlist name. Example: a playlist from shared name “James” would show as “Jame:Rock Hits.”

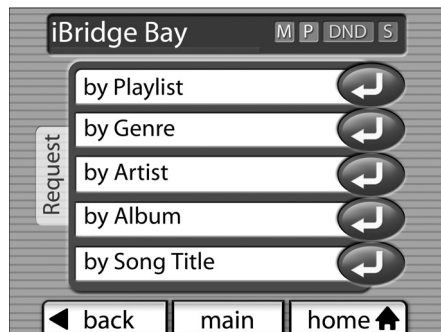

Operation

RNET system controls within an audio zone using a Russound SRC2 remote control

Use the RNET remote control to navigate through your iTunes music library playlists via the iBridge Bay.

Aim the SRC2 at the keypad or touchscreen, press “R” and then the power button located on the upper right hand corner of the SRC2 (if the keypad/touchscreen is off).

Select the iBridge Bay by choosing its corresponding source number button located on the lower half of the SRC2.

To pause a song, press the 'pause' button.
To resume a paused song, press either 'play' or 'pause'.

To scroll through iTunes playlists, use the channel “+” and “-” buttons to scroll up and down.







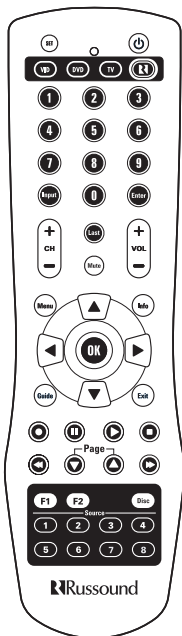



To select 'previous song' and 'next song' press the 'next' and 'previous' buttons.

To search forward and search back within a track, press and hold the 'next' or 'previous' buttons.

SRC2 Remote Control Function Keys



RNET System Control

-  POWER button - Turns Russound system zones on and off.
-  RUSSOUND SYSTEM button - Activates control of Russound system controller and keypads, and connected sources
-  VOLUME UP/DOWN - Raises and lowers the volume for the room you are in
-  CHANNEL UP/DOWN - Navigates up and down playlists
-  **1 - 8** SOURCE SELECTION BUTTONS - Selects Russound source to control with the SRC2 remote control
-  PAUSE - Pauses/unpauses selected media
-  PLAY - Accesses NOW PLAYING and SHUFFLE MODE
-  STOP - Exits NOW PLAYING and SHUFFLE MODE
-  PREVIOUS TRACK- (press) Skips to previous track in playlist. (press and hold) Search back.
-  NEXT TRACK - (press) Skips to next track in playlist. (press and hold) Search forward.

Operation

Remote navigation through Front Row from a video equipped zone using a Russound SRC2 remote control

The iBridge Bay allows you to access media through Apple Front Row software in zones equipped with a video display.

With the video display powered on, aim the SRC2 at the keypad or touchscreen, press “R” and then the power button located on the upper right hand corner of the SRC2 (if the keypad/touchscreen is off).

Select the iBridge Bay by choosing its corresponding source number button located on the lower half of the SRC2.

To rotate around Front Row media types (music, videos, DVD, photos) use the left and right arrow buttons.

To select, press the 'OK' button when the desired media type is located in the foreground of the video display.







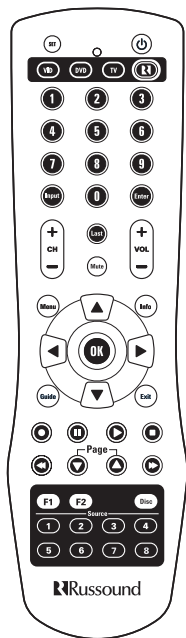

Use the up and down arrow buttons to navigate menus within a media type.

To select from a menu, press the 'OK' button. Use the 'Menu' button to navigate backwards.

SRC2 Remote Control Function Keys









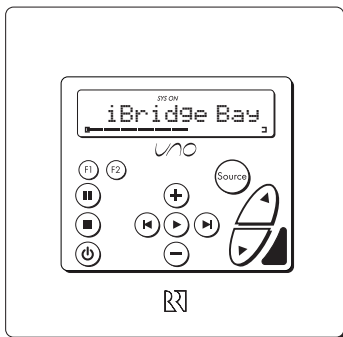

Front Row Controls

- 
MENU - Toggles between Front Row menu and iBridge Bay screen saver. Also navigates backwards through menus.
- 
OK - Selects highlighted option. Also performs Play/Pause on Front Row Now Playing screens.
- 
UP ARROW - Navigates through Front Row menus.
- 
DOWN ARROW - Navigates through Front Row menus.
- 
RIGHT ARROW - Skips to next track/photo/chapter in list.
- 
LEFT ARROW - Skips to previous track/photo/chapter in list.
- 
PREVIOUS - Press and hold to search back through a track or scene (iTunes only).
- 
NEXT - Press and hold to search forward through a track or scene (iTunes only).

Operation

UNO-S2 Keypad Control



-  **PLAY** - plays paused media, accesses NOW PLAYING to display information for media playing, pressing a second time accesses SHUFFLE MODE.
-  **STOP** - Exits NOW PLAYING menu.
-  **PAUSE** - pauses media playing, resume play of paused media.
-  **NEXT TRACK** - (press) selects next track, scrolls through artist, album, and song title in NOW PLAYING mode, toggles shuffle off or on in SHUFFLE mode. (press and hold) Search forward.
-  **PREVIOUS TRACK** - (press) selects previous track, scrolls through artist, album, and song title in NOW PLAYING mode, toggles shuffle off or on in SHUFFLE mode. (press and hold) Search back.
-  **PLUS** - scrolls up through playlists.
-  **MINUS** - scrolls down through playlists.

Installing iBridge Bay Application

Note: The iBridge Bay Application software must be installed on the Mac before the iBridge Bay is connected to the Mac and the RNET system.

1. With the Mac turned on and connected to a monitor and mouse, insert the iBridge Bay Application CD into the CD/DVD drive.
2. Double click on the CD icon to reveal the iBridge Bay Application icon. Next, double click on the hard drive icon located in the upper right hand corner of the Mac's desktop to open the hard drive folder. Next, drag the iBridge Bay Application icon into the Applications folder in the hard drive folder.
3. When file transfer is complete, eject the CD by dragging the CD icon on top of the Trash on the Mac's desktop toolbar.
4. To configure settings, click on the Apple icon in the top left hand corner of the Menu Bar. Select System Preferences. From the Hardware section, select Bluetooth. Un-check the box labeled "Open Bluetooth Setup Assistant at startup when no input device is present." Click the back arrow to return to the Hardware section. From the Hardware section, select Energy Saver. Go to the Options tab. Under Other Options check the box labeled "Restart automatically after a power failure."
5. Close all open applications. Click on the apple icon in the left hand corner of the Menu Bar. Select 'Restart.' After the computer restarts, the iBridge Bay Application will start automatically.



Bluetooth Settings

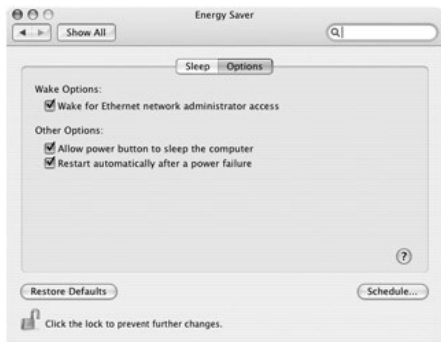

Energy Saver Settings

Hardware Installation

iBridge Bay Rear View

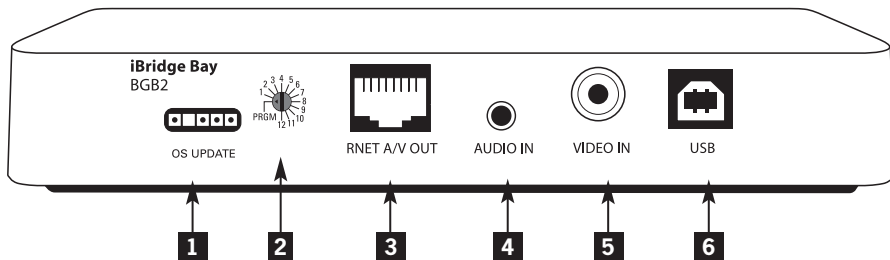

- 1** OS UPDATE PORT – 4-pole connector for updating device firmware with programming cable, Russound part number 2500-521065
- 2** SOURCE/FUNCTION SELECTOR – 13-position switch for selecting source number input or PRGM for firmware update. For use of multiple BGB2s on one RNET system, assign each unit a unique source number.
- 3** RNET A/V PORT – RJ-45 connector for RNET A/V Decoder
- 4** AUDIO IN – 3.5 mm stereo jack
- 5** VIDEO IN – RCA composite video connection
- 6** USB PORT – USB type B

Installing Hardware

Note: The iBridge Bay requires the use of an RAVD1 RNET A/V Decoder to connect to a Russound RNET system.

1. Place the iBridge Bay with the Mac computer it will be used with. Place the RNET Decoder with the RNET controller amplifier.

2. Install CAT-5e cable between the iBridge Bay and the Decoder, up to 300 feet (90 m). Terminate CAT-5e cable ends using RJ-45 connectors, following the T568A standard as shown. If desired, use modular wall plates and RJ-45 patch cables for a neater appearance. Connect the iBridge Bay to the Decoder by connecting CAT-5e cable to the RNET A/V jacks located on each device.

3. Connect Decoder to the RNET system according to the RAVD1 A/V Decoder manual.

4. Set the Source/Function Selector switch on the back of the iBridge Bay to match the source number that the RAVD1 Decoder cables are plugged into on the back of the RNET controller. PRGM is used solely for firmware updates. When these updates become available, they can be downloaded from the Document Center at www.russound.com.

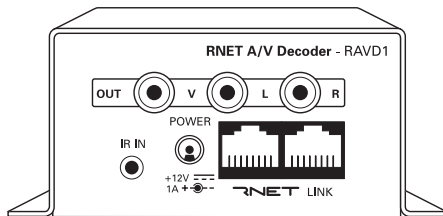

RNET A/V Decoder

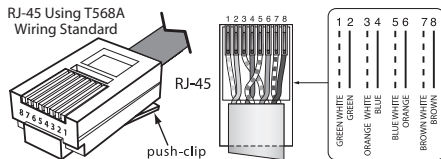

RJ45 wiring with T568A standard

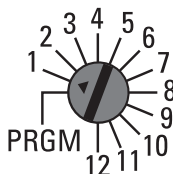

Source/function selector switch

Hardware Installation

Installing Hardware (continued)

5. Connect the iBridge Bay to a Mac using a USB type A to type B cable. Turn on the Mac computer to power up the iBridge Bay. The iTunes and iBridge Bay Application software will automatically launch.
6. Power up the RNET controller amplifier and select the source you're using for the iBridge Bay from a keypad. As long as iTunes is playing, you should hear it through the audio system.
7. Using the RNET system's programming instructions, configure the iBridge Bay source as a PERIPHERAL command type device.
8. If the system includes UNO-TS2 touchscreens, also use the Screen Setup feature in the UNO-TS2 Installer Setup menu to configure the Bay as an iPod (iBridge) source type to assign the correct screen template.

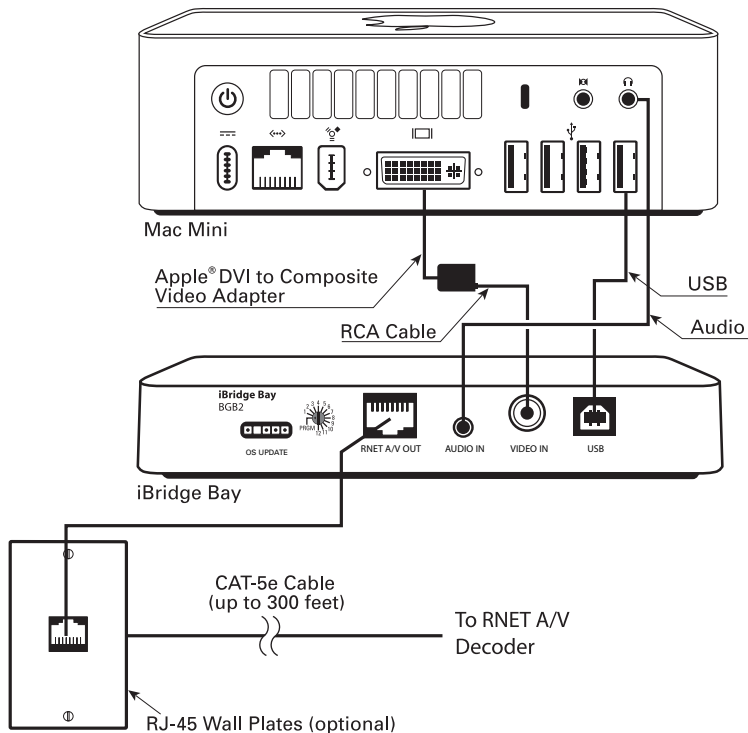

Connection Overview Diagram

Troubleshooting

System Troubleshooting

Unable to control the Bay through system key-pads, touchscreens, or with remote control.

Make sure the iBridge Bay application is running. Confirm that RNET system firmware is up to date. Check that the Source/Function Selector switch setting on the back of the iBridge Bay matches the source number that the RAVD1 Decoder cables are plugged into on the back of the controller.

Also, check the controller programming settings to ensure that the Bay's source command type is "PERIPHERAL."

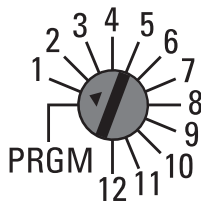

Front Row exiting to iTunes unexpectedly

When a new shared library becomes available on your network, the iBridge Bay application will exit Front Row to refresh the available playlists. After iTunes has updated the playlists, the Mac will return to Front Row.

iBridge Bay Status screen shows "Bay connection status: Not Connected"

If the Bay connection status indicator is red, the iBridge Bay Application on the Mac cannot communicate with the iBridge Bay. Please check the USB connection between the iBridge Bay and the Mac computer.

If the cable appears to be connected correctly and the problem persists, you may have a defective cable or USB terminal.



Problems with default *Options* settings

If the iBridge Bay default *Options* settings have been changed, this may trigger a variety of issues such as the iBridge Bay application not launching at system log in, Front Row not loading at start-up, or source volume level too low.

To change these settings back to the default, click on the Russound logo (arrow) located on the application dock typically located at the bottom of the Mac's desktop screen.

When the iBridge Bay window opens, select *Options*. From the *Options* window, make sure that all choices are selected, as shown in screen shot.



Mac "goes to sleep" (hard drive or display)

Click on the Apple icon in the top left hand corner of the Menu Bar. Select "System Preferences." Under "Hardware" select "Energy Saver." Under the "Sleep" tab set both the computer and display sleep sliders to Never.

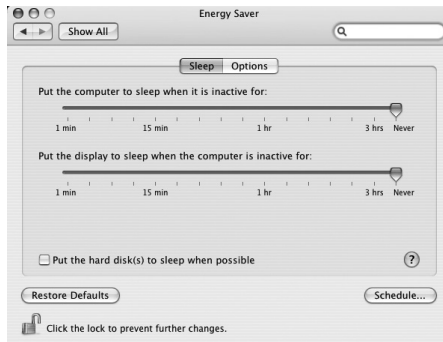

Troubleshooting

Apple updates interfering with iBridge Bay operation

Click on the Apple icon in the top left hand corner of the Menu Bar. Select "System Preferences." Under "System" select "Software Update." Under the "Update Software" tab uncheck "Check for updates."



Specifications and Warranty

Specifications

Switch:	13-position source/function selector
RNET A/V connector:	8-pole modular RJ45 jack
OS Update Port connector:	4-pole jack for Programming Cable, Russound part #2500-521065
Power requirement:	5 VDC 100 mA USB
Dimensions:	6.56" W x 6.56" D x 1.0" H (16.7 x 16.7 x 2.5 cm)
Weight:	7.2 oz (204 g)

Supported Mac Models

For Intel Core Duo equipped computers running OS X 10.4 or higher

- iMac®
- Mac mini
- Mac Pro
- MacBook®
- MacBook Pro

Warranty

The Russound iBridgE Bay is fully guaranteed against all defects in materials and workmanship for two (2) years from the date of purchase. During this period, Russound will replace any defective parts and correct any defect in workmanship without charge for either parts or labor. For this warranty to apply, the unit must be installed and used according to its written instructions. If service is necessary, it must be performed by Russound. The unit must be returned to Russound at the owner's expense and with prior written permission. Accidental damage and shipping damage are not considered defects, nor is damage resulting from abuse or from servicing by an agency or person not specifically authorized in writing by Russound.

This warranty does not cover: damage caused by abuse, accident, misuse, negligence, or improper installation or operation; power surges and lightning strikes; normal wear and maintenance; products that have been altered or modified; any product whose identifying number, decal, serial number, etc. has been altered, defaced or removed.

Russound sells products only through authorized dealers and distributors to ensure that customers obtain proper support and service. Any Russound product purchased from an unauthorized dealer or other source, including retailers, mail order sellers and online sellers will not be honored or serviced under existing Russound warranty policy. Any sale of products by an unauthorized source or other manner not authorized by Russound shall void the warranty on the applicable product.

Damage to or destruction of components due to application of excessive power voids the warranty on those parts. In these cases, repairs will be made on the basis of the retail value of the parts and labor. To return for repairs, the unit must be shipped to Russound at the owner's expense, along with a note explaining the nature of service required. Be sure to pack the unit in a corrugated container with at least three (3) inches of resilient material to protect the unit from damage in transit. Before returning a unit for repair, call Russound at 603.659.5170 for a return authorization number. Write this number on the shipping label and ship to: Russound, 5 Forbes Road, Newmarket, NH 03857.



BGB2 iBridge Bay Instruction Manual



5 Forbes Road, Newmarket NH 03857 USA
Tel 603.659.5170 • Fax 603.659.5388
www.russound.com

Apple, iMac, iTunes, Mac, MacBook is a trademark of Apple Inc., registered in the US and other countries.